

TN-1 / TN9-1 TUNNEL NET CLIMBER

JAMMAR MFG

The Tunnel Net Climber is a heavy duty A-frame and tunnel net designed for physical education and adaptive PE children providing crawling skills within a moving and challenging enclosed net environment. Traverse at each child's individual skill and comfort level.

Frame is constructed of heavy duty 1-1/2" galvanized steel pipe and features a unique "fold down" design allowing for easy setup, breakdown, transport and compact storage. Frame locks into position with quick-release pins and includes rubber feet for floor protection. Climber can easily be moved by two adults. Tunnel is handcrafted using 3/4" yellow polypropylene rope (other colors available). Width of tunnel is easily controlled by adjusting the side tie-offs. Handcrafted net is available with 12" or 9" square openings. Climber recommended for indoor use but is also suitable for limited outdoor use. Ample lashing cord provided to control desired net tension.

Do not allow any jumping on or off the net or net surface. Proper mats, supervision, and spotting required when using the equipment.

SPECIFY DESIRED NET MESH SIZE

- TN-1 12" SQUARE MESH AND FRAME
- TN9-1 9" SQUARE MESH AND FRAME

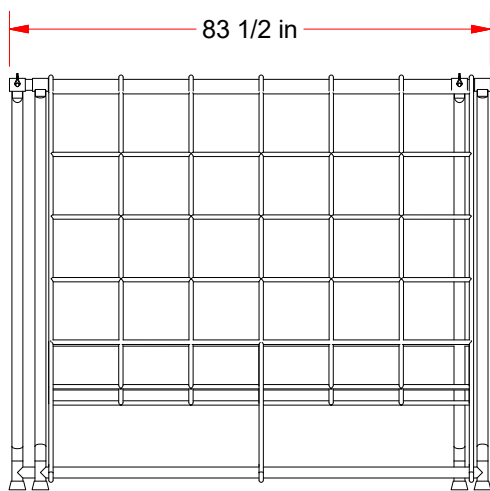
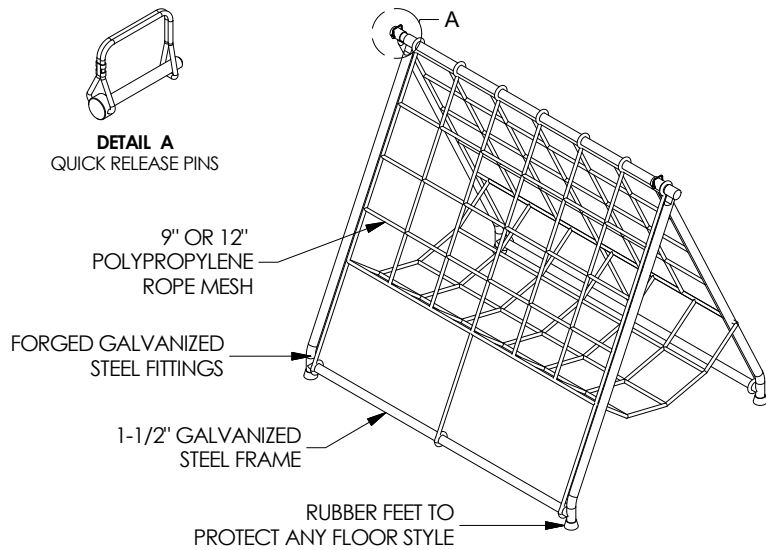

FRONT VIEW

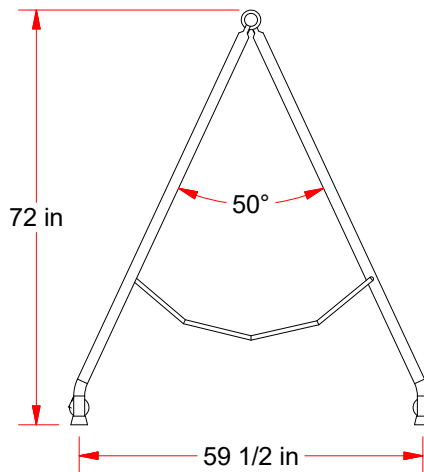

SIDE VIEW

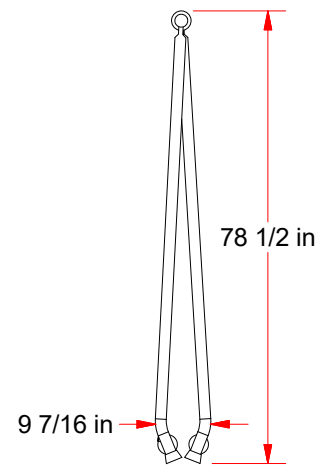

STORAGE VIEW

www.jammarmfg.com
26 Industrial Park Road
Niantic, CT 06357
P: (860) 451-8163 F: (860) 451-8178



ALL RIGHTS RESERVED. THIS PRINT IS THE SOLE PROPERTY OF JAMMAR MFG AND MAY NOT BE REPRODUCED WITHOUT WRITTEN PERMISSION. © COPYRIGHT 2017 JAMMAR MFG INC.

PRODUCT SPECIFICATION